

PS2-600 HR-07 Energy-1

Solar Submersible Pump System for 4" wells for leachate extraction and remediation

System Overview

Head	max. 50 m
Flow rate	max. 1,4 m ³ /h

Technical Data

Controller PS2-600 Energy

- Controlling and monitoring
- Control inputs for dry running protection, remote control etc.
- Protected against reverse polarity, overload and overtemperature
- Integrated MPPT (Maximum Power Point Tracking)
- Battery operation: Integrated low voltage disconnect

Power	max. 0,70 kW
Input voltage	max. 150 V
Optimum Vmp**	> 68 V
Motor current	max. 13 A
Efficiency	max. 98 %
Ambient temp.	-40...50 °C
Enclosure class	IP68

Motor ECDRIVE 600-HR Energy

- Maintenance-free brushless DC motor
- Water filled
- Premium materials, stainless steel: AISI 304/316
- No electronics in the motor

Rated power	0,7 kW
Efficiency	max. 92 %
Motor speed	900...3.300 rpm
Insulation class	F
Enclosure class	IP68
Submersion	max. 150 m

Pump End PE HR-07 Energy-1***

- Non-return valve
- Premium materials, stainless steel: AISI 304/316
- Helical rotor pump
- Sacrificial anode included

Efficiency	max. 62 %
------------	-----------



Pump Unit PU600 HR-07 Energy-1 (Motor, Pump End)

Borehole diameter	min. 4,0 in
Fluid temperature	max. 60 °C

Standards



2006/42/EC, 2004/108/EC, 2006/95/EC

IEC/EN 61702:1995

The logos shown reflect the approvals that have been granted for this product family. Products are ordered and supplied with the approvals specific to the market requirements.

**Vmp: MPP-voltage under Standard Test Conditions (STC): 1000 W/m² solar irradiance, 25 °C cell temperature

***Specify temperature range on order



PS2-600 HR-07 Energy-1

Solar Submersible Pump System for 4" wells for leachate extraction and remediation

Pump Chart

Vmp* > 68 V

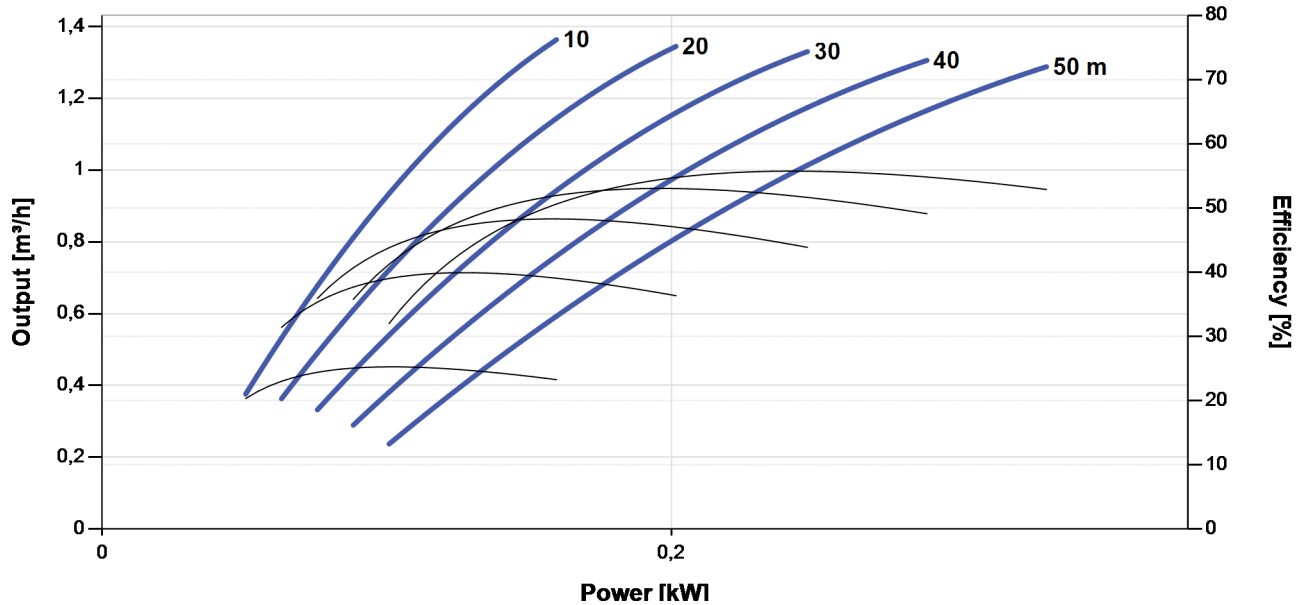

Dimensions and Weights

Controller

H1 = 352 mm
 H2 = 333 mm
 W1 = 207 mm
 W2 = 170 mm
 W3 = 164 mm
 D1 = 124 mm

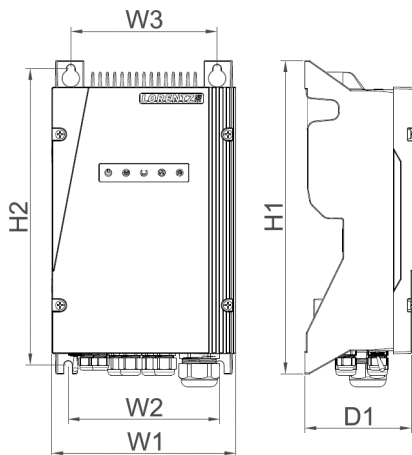

Pump Unit**

A = 1.010 mm
 B = 190 mm
 C = 820 mm
 D = 96 mm
 E = 147 mm
 S = 1,25 in

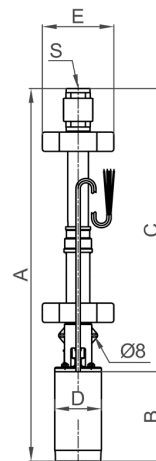

	Net weight
Controller	5,6 kg
Pump Unit	13 kg
Motor	7,0 kg
Pump End	5,5 kg

*Vmp: MPP-voltage under Standard Test Conditions (STC): 1000 W/m² solar irradiance, 25 °C cell temperature

**By cutting the rubber spacers the diameter can be adjusted between 6" and 4" wells.

