

EN FR ES



**S1-700**  
**Motor Extension Cable**  
20 m / 66 ft  
Item# 19-005600



EN FR ES

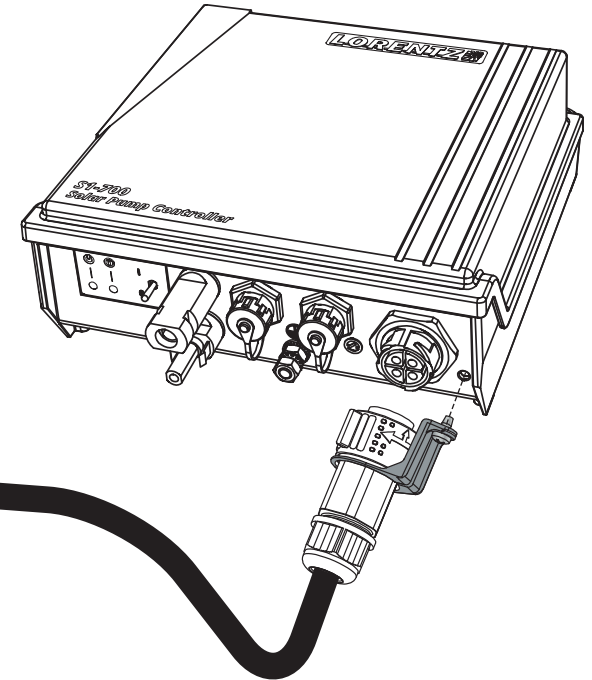

Some products are not available in all markets

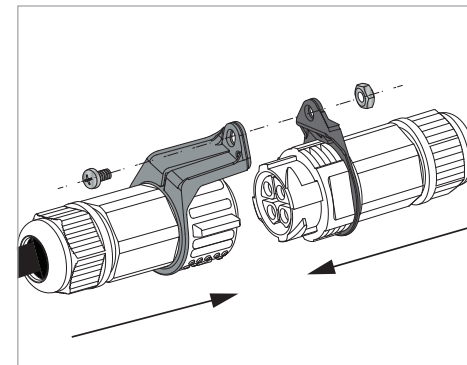
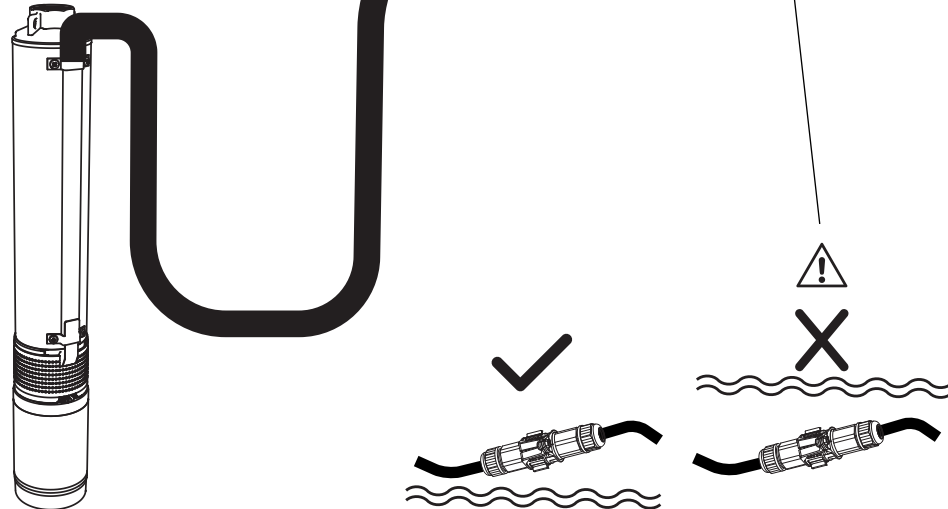

We recommend to use one extension cable. Using multiple extension cables will reduce system performance.

Nous vous recommandons d'utiliser un seul câble d'extension. L'utilisation de plusieurs câbles d'extension réduira les performances du système.

Se recomienda utilizar una sola extensión de cable. El uso de varias extensiones reducirá el rendimiento del sistema.

**PT IT DE AR**



**S1-700**  
**Motor Extension Cable**  
 20 m / 66 ft  
 Item# 19-005600



**PT IT DE AR**

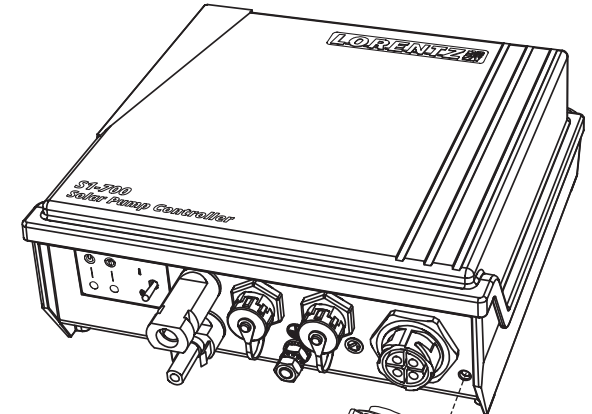

Some products are not available in all markets

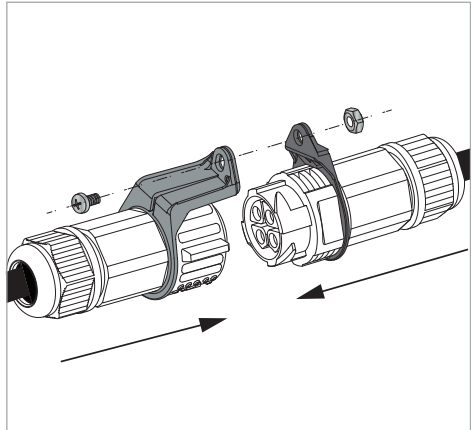
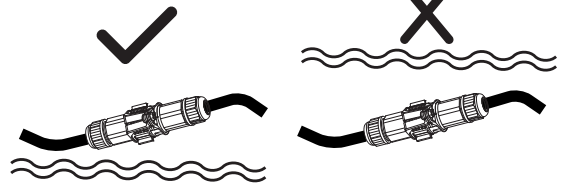
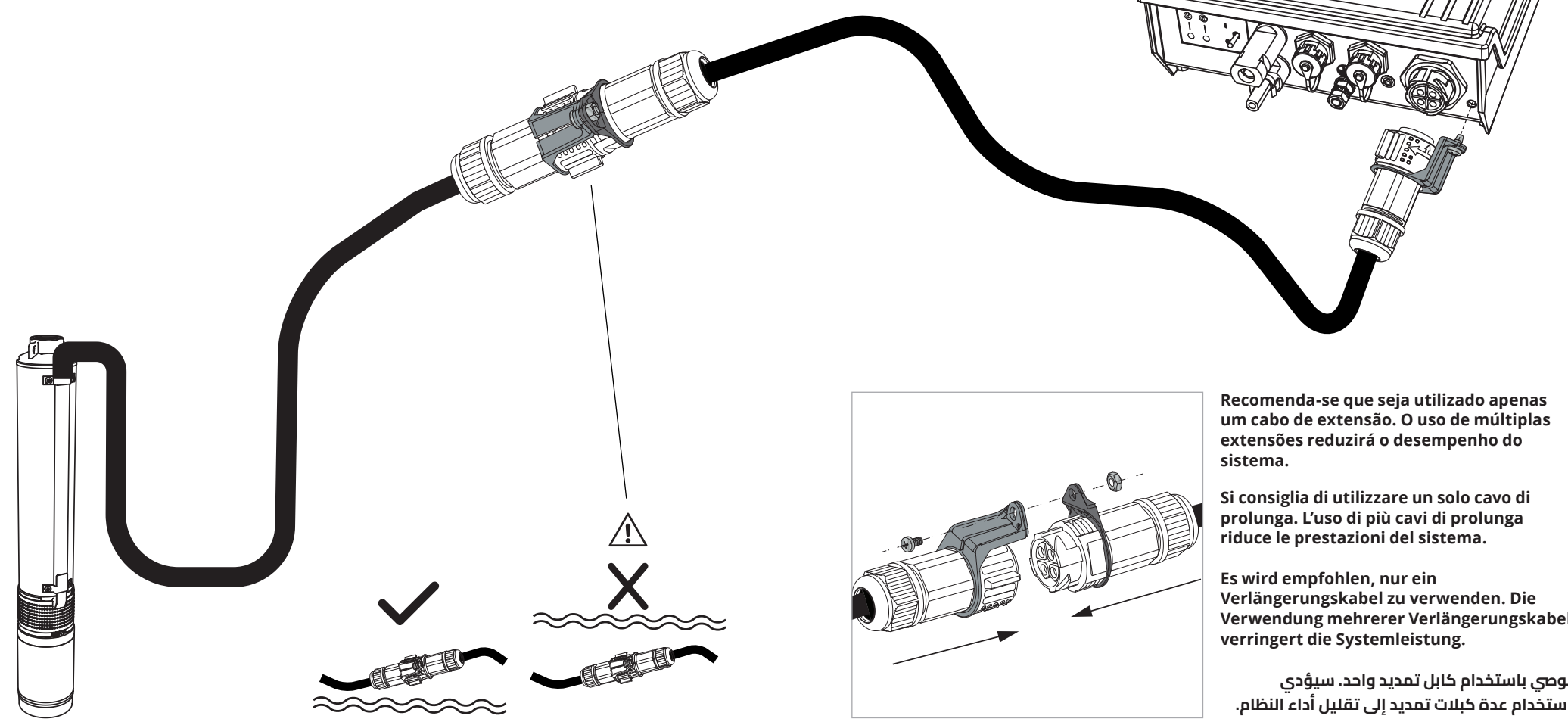

Recomenda-se que seja utilizado apenas um cabo de extensão. O uso de múltiplas extensões reduzirá o desempenho do sistema.

Si consiglia di utilizzare un solo cavo di prolunga. L'uso di più cavi di prolunga riduce le prestazioni del sistema.

Es wird empfohlen, nur ein Verlängerungskabel zu verwenden. Die Verwendung mehrerer Verlängerungskabel verringert die Systemleistung.

نومي باستخدام كابل تمديد واحد. سيؤدي استخدام عدة كبلات تمديد إلى تقليل أداء النظام.